



Press release – July 2005

## Seismic Protection for Buildings: Onassis-House and Akropolis-Museum

Innovative Sliding Isolation Pendulum Bearings pass seismic tests

Munich/Athens. **With the help of 2 prestigious projects, Maurer Söhne Munich enters a new market; both for the Onassis House of Fine Arts and for the new Akropolis Museum in Athens, innovative Sliding Isolation Pendulums (SIPs) will be delivered. After comprehensive tests in the test laboratory of the University of California in San Diego, MAURER could prove that the SIPs could pass the special requirements in earth quake conditions, and so, as a result, Maurer Söhne received the order from the Onassis House of Fine Arts as a pilot project. During the approval process, the innovative sliding material named MSM – MAURER Sliding Material - played a decisive role.**

Generally speaking, there are 2 ways to safely design a building against seismic conditions. One way is to design a structure in a ways that it withstands a seismic impact, which means that the structure must be flexible, and vibrations and deflections caused by seismic input must be damped. The alternative way is that the seismic attack fails to reach the structure at all. With its SIP bearings, Maurer Söhne follows the alternative way.

### **Sliding – Isolating - Recentring**

SIP-bearings can be compared to a spherical bearing that can move in all directions. What is new is the fact that the upper sliding plate also employs a curvature. The term “Sliding Isolation Pendulum” describes the four functionalities of this type of bearing:

- “Sliding” stands for the fact that horizontal displacements caused by seismic events are accommodated by the sliding movement, and in the same time the energy that is introduced is converted either into heat or into potential energy.



- “Isolation” describes the isolating effect of the bearings. That is, in case of a seismic event, the bearings isolate the building from its ground. That is, the movement of the earth quake will not move the structure, but it stays “quiet” and will not suffer a damage.
- “Pendulum” stands for the recentring effect. In case the bearings were displaced by means of a seismic impact, the building recenters itself like a pendulum by means of its dead weight into the central position of the curved sliding surface. This is an important function, in particular when the seismic attack always acts into the same direction.
- “Bearing” stands for the transmission of loads. A Sliding Isolation Pendulum employs the special feature that the isolation effect does not depend on the mass of the structure, and the bearing can be dimensioned in an optimum manner, that is both for the unloaded case and under full load.

So, SIP-bearings combine the 4 main requirements of a seismic isolation in just 1 unit:

- vertical load transmission
- horizontal displacement
- energy dissipation
- recentring

With the pilot project “Onassis House of Fine Arts and Letters”, Maurer Söhne developed the SIP bearings into series-production readiness. The initiative came from the Onassis Foundation, which is the biggest private investor in Greece. Contractor is a daughter company of the Onassis Foundation named Ariona Athens. The Greek already knew MAURER to be bearing specialists in the field of bridge construction. For this order, condition was however that the performance capacity of the individual materials and the functionality of the SIPs was checked and tested by independent test laboratories.

### **Strict Quality Control**

Maurer Söhne accepted this challenge in respect to quality. The first material tests were conducted at the Materials Testing Institute of the Stuttgart



University (MPA). End of April 2005, prototypes of the SIP bearings were tested end at the world wide unique shake table of the seismic test lab of the University of San Diego/USA. Each of the 4 test bearings was subject to 8 real seismic events of the three fold magnitude of the El-Centro-Earth Quake, and movements in all 3 directions were simulated. To date, no similar tests are known that were conducted with comparable bearings. Also the Greek contractors who witnessed the tests were convinced by the superior performance of the bearings, and consequently the order was awarded to Maurer Söhne.

A decisive role was played by the sliding material MSM – MAURER Sliding Material. Even under seismic attack, MSM displays a controlled behaviour in terms of sliding friction, and this at different contact pressures and at different displacement velocities. Thereby, the friction coefficient has to remain within an exactly defined window. Friction is required to convert the movement energy caused by the earth quake into heat, this is why the MSM bearings will not be greased in this case. In the same time, the friction may not increase by too much, otherwise the recentring effect will no longer be guaranteed. It is the size of the bearings that control the magnitude of contact pressure and friction. MSM which displays almost no wearing effects facilitates the adoption of several earth quakes without the need to replace the sliding material.

In case of earth quake, in Athens an acceleration of up to 0.63 g has to be taken into account. The bearings for the Onassis House are dimensioned for a service load of 11,000 kN, the maximum load in case of a seismic event is 25,000 kN. The maximum horizontal displacements are +/- 255 mm.

The “Onassis House of Fine Arts and Letters” will house an opera, and several art galleries. In ground view, it measures 65 m by 30 m, and it will have 7 storeys. The slab towards the base floor will be executed double, and between these 2 base slabs, the 48 SIP bearings will be placed. The bearings employ a diameter of 1,100 mm and a height of 380 mm. Friction coefficient is



between 4% and 6%. The bearings will be installed by end of August 2005, and the building shall be inaugurated in June 2007.

### **Good performance brings about a new order**

The superior performance of the SIP bearings in San Diego earned Maurer Söhne the next order, also in Athens. For the Akropolis Museum, which is located at the Southern edge of the Akropolis, 94 SIP bearings with a vertical load of up to 16,000 kN and a movement capacity of +/- 250 mm were ordered. The seismic bearings will be installed underneath a concrete base plate of a dimension of 110 m by 70 m, on which the 40 m high building will be constructed – a light-flooded steel-glass structure, from which a view to the Akropolis is possible. Main attraction of the museum will be Parthenon statues that will be returned by the British Museum. The ground floor is planned to harbour moving exhibitions, in the central area the time range of the Antique period to the Roman Period will be displayed, and at the top a cafeteria and a restaurant will be located.

Owner of the building is OANMA, and the executing contractor shall be the company "Alte". Delivery of the bearings is planned for September 2005.

#### **Contact for Press:**

**Dr..Christian Braun**, Maurer Söhne Structural Protection Systems Division, Frankfurter Ring 193, D 80807 Munich, Germany.

Phone 089/32394-268, Fax 089/32394-306, E-Mail braun@mchn.maurer-soehne.de, www.maurer-soehne.de

MAU\_PR\_Athen\_Grafik.jpg

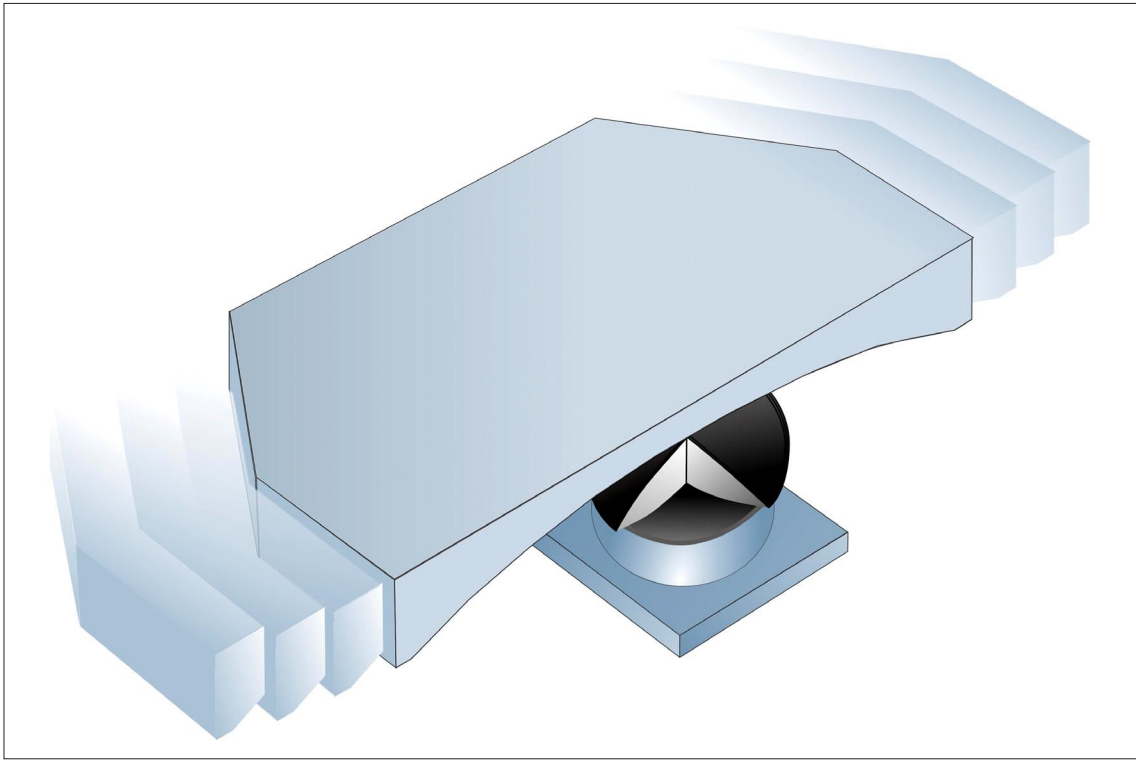

Cross section through the SIP bearing, as it was designed for the 2 structures in Athens. A characteristic feature is displayed in the curvature in the upper sliding surface. By way of this curvature, the structure recenters itself after a lateral seismic attack into its central position (pendulum effect).

Graphic: Maurer Söhne

MAU\_PR\_Athen\_Lagereinbau.jpg



Bearing installation at the shake table of the seismic test laboratory of the University of California in San Diego, USA. Here to be seen the special calotte with its 2 curvatures above and below.

Photo: Maurer Söhne

MAU\_PR\_Athen\_Akropolis.jpg



Model of the future Akropolis Museum. The sliding isolation pendulum bearings will be installed underneath the concrete base plate, on which the 40 m high building will be constructed.

Photo: Maurer Söhne